

Fast and
energy saving

TDR 5 Programmable eco

The Turbo Deli Rotisserie is the fastest original rotisserie in the industry. The TDR's cavity is fed with air, cooking a rotisserie chicken as it is meant to be: crispy and delicious while maintaining an attractive appearance for hours.

The TDR pushes the air throughout the cavity, resulting in an improved heat transfer on the products and consequently in a reduced electricity consumption during the preparation process.

Thanks to eco-cooking the TDR saves 5% additional energy. Add to this the improved heat transfer on the products and a fast preparation process and you have yourself the most energy-efficient rotisserie with a high output.

Cook Correction corrects alterations in the cooking cycle that are due to half-loads, overloads, or products with a difference in temperature. It measures abnormalities in the temperature curve and corrects the cycle automatically, ensuring food-safety and energy-efficient cooking.



Programmable controls



Large product view



Features TDR 5 Programmable

Top features

- Controls with programmable settings
- 99 programs with up to 3 cook stages per program
- Cook Correction controls food safety and saves 5% on energy
- Eco Cooking, saves an additional 5% on energy consumption

Standard characteristics

- 5 Meat fork, V-spit, basket or rack positions
- Rotor for up to 20 chickens (1,2 kg) per batch
- USB connection for easy transfer of data and programs
- Boost functionality to add extra time
- Outstanding food quality: high-speed convection for even cooking
- Outstanding food quality: radiant heat for uniform browning
- Striking cooking theatre due to large glass surface and brilliant lighting
- Safety stop when opening the door
- No water and drain connections needed

Accessories

- Meat forks (included)
- Multi-purpose baskets
- V-spits and chicken racks
- Matching stand on castors

Optional

- Stacked unit
- Pass-through
- Ventless hood



Ventless hood (optional)



Stacked TDR

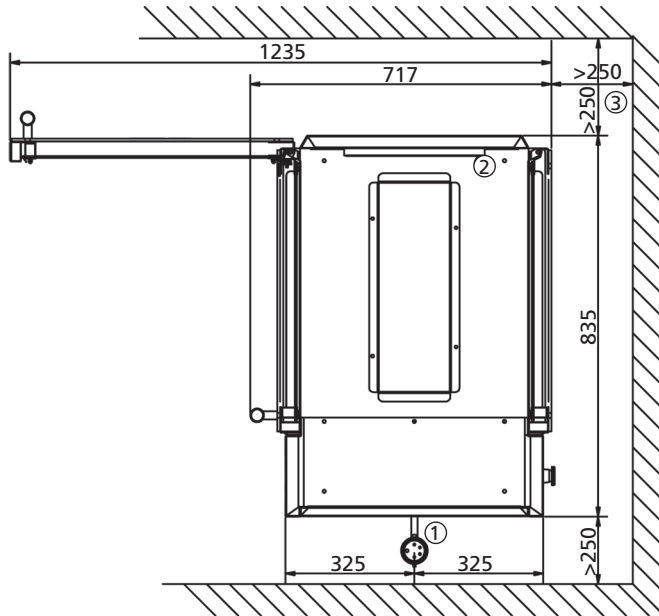

TDR 5 Programmable

- 1 Power cable, 2.2 m
- 2 Exhaust opening
- 3 Space to the wall
- 4 Location for socket

Dimensions TDR 5

Width	835 mm
Depth	717 mm
Depth with hood	853 mm
Height	910 mm
Height on stand	1725 mm
Height with hood	1245 mm

Technical data TDR 5

Net weight	130 kg
Gross weight	152 kg
Voltage	3N~ 400/230 V
Frequency	50/60 Hz
Power	6.6 kW

Dimensions TDR 5+5

Width	835 mm
Depth	717 mm
Depth with hood	853 mm
Height	1790 mm
Height with hood	2124 mm

Technical data TDR 5+5

Net weight	266 kg
Gross weight	306 kg
Voltage	3N~ 400/230 V
Frequency	50/60 Hz
Power	13.2 kW

Specifications and technical data are subject to amendment without prior notice.

These are basic drawings. For more detailed technical information, please refer to the installation manual at www.frijado.com.

